

# Analogue Weatherproof Telephone with LED

## Description

- SMC housing with high mechanical strength and impact resistance.
- Heavy duty handset with hearing aid compatible receiver, noise canceling microphone.
- Silicone rubber keypad and magnetic hook switch.
- Full keypad with memory, 0-9 buttons can be programmed as speed dial button.
- Rotation mounting closure, weatherproof grade is IP67.
- Beacon and loudspeaker option.
- Lightening protection to ITU-T recommendation K.21.
- Powder coated in UV stabilized polyester finish.
- The size and style of weatherproof telephone can be customized according to customer demand.



## Specification

- **Ambient Temperature:** -30 ~ +70 degree celsius
- **Relative Humidity:** 10% ~95%
- **Atmospheric Pressure:** 86 - 106kpa
- **Sound Level of Ringing:** >80dB(A).
- **Standard Frequency:** Low frequency group 697, 770, 852, 941Hz. High frequency group 1209, 1336, 1477Hz.
- **Frequency Deviation:** -1.5% ~ +1.5%
- **Call Transmission Index:** (5km) SLR<12, RLR<-1, STMR>10, output impedance is 600ohm.
- **Applicable** for various types of PABX with feeding voltage of 33-60V
- **MTBF:**100,000 hours.
- **MTTR:** 2 hours.

## Applications

- The telephone is generally used in different work areas like tunnels, trackside, oil&gas, shipboard, bridge, power plants, poolside, etc.



## Installation

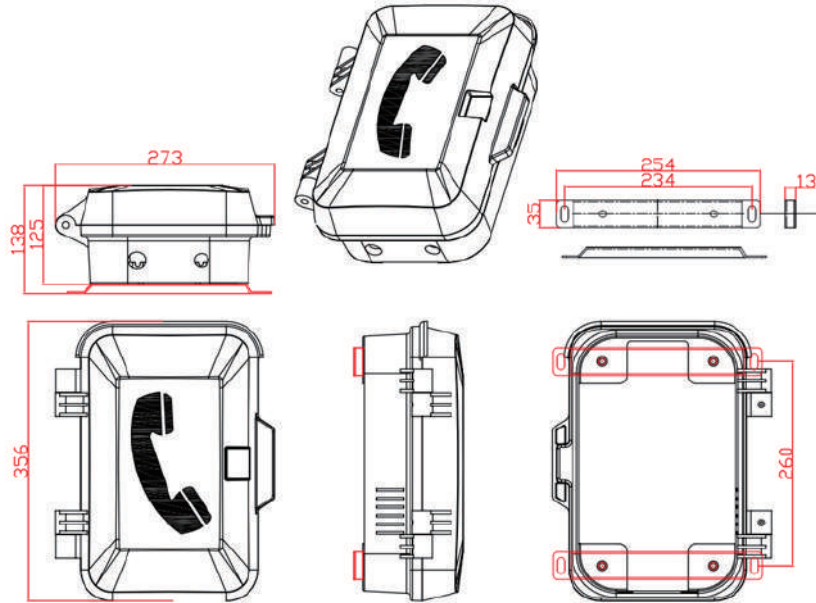

## Operation

- Please pick up the handset. After dial tone is heard using the keypad to dial your number.
- Normal telephone operation follows.

## Packing

**Unit size:** 356x273x125mm

**Net weight:** 6.9kg

**Packing size:** 370x300x150mm

**Gross weight:** 7.5kg

**Packing box:** Carton box

## Information

Item Description
Telephone for Boats & Industrial Area
Telephone with loudspeaker +beacon
Telephone for Public
Telephone for Prison

## Warranty

36 months of defect warranty by manufacturer.



Please consult brochure for more information or visit:  
[www.kalemisbros.com](http://www.kalemisbros.com) Email: [info@kalemisbros.com](mailto:info@kalemisbros.com)  
 Tel: +30 2105773301